

REVISIONS			
REV	DESCRIPTION	DATE	APPROVED
0	PRODUCTION RELEASE	5/20/2022	RJM

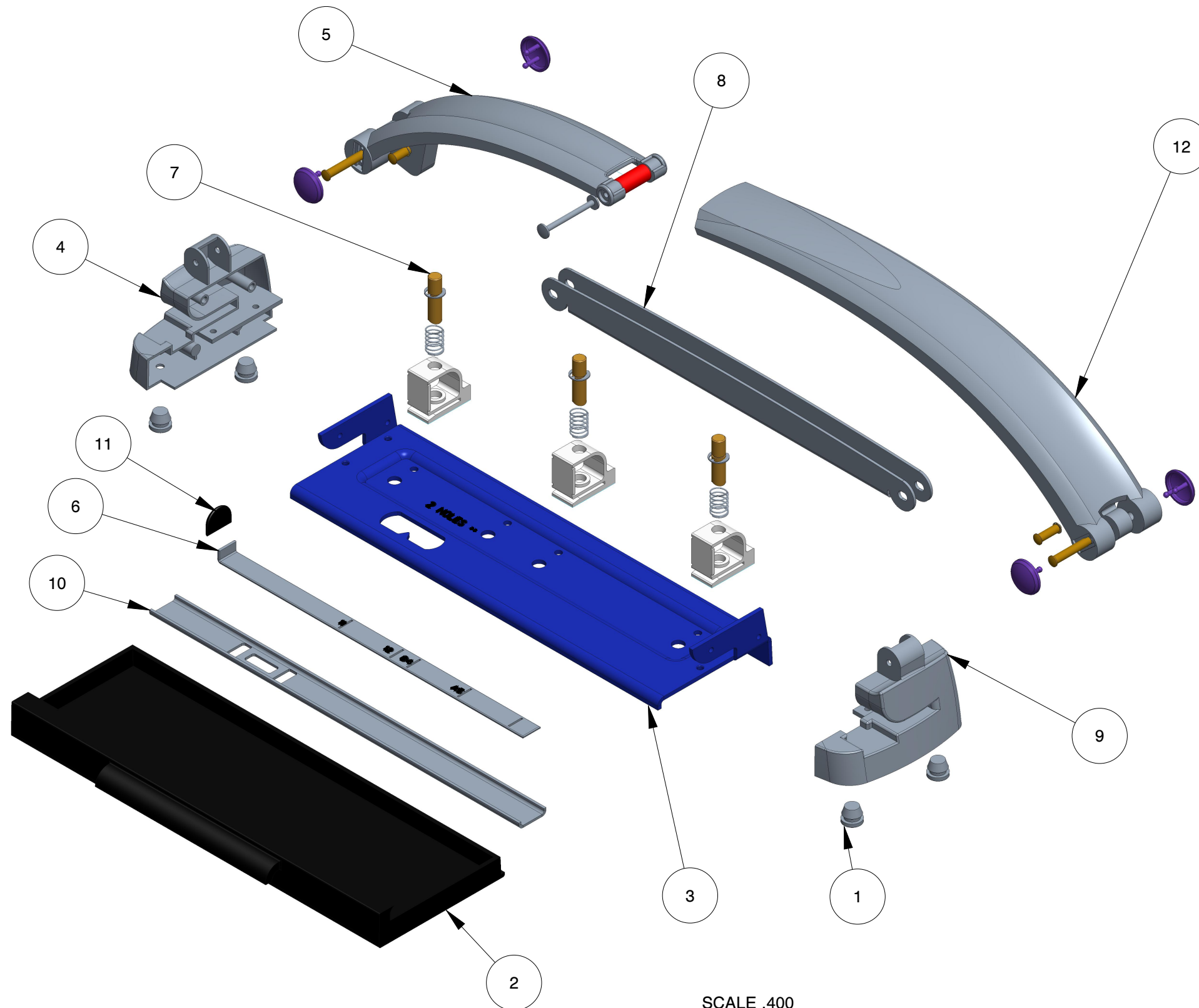

SCALE .400

ITEM NO	QTY	MODEL NAME	DESCRIPTION
1	4	BOTTOM-FEET	BASE END FEET
2	1	BOTTOM-TRAY	BOTTOM CATCH TRAY
3	1	CENTER-PLATE	CENTER PLATE
4	1	L-BASE-END	BASE LEFT END
5	1	LOWER-HANDLE-ASM	LOWER HANDLE ASSEMBLY
6	1	PAPER-STOP	PAPER STOP
7	3	PUNCH-ASM	PUNCH ASSEMBLY
8	1	PUSHBAR	PUNCH PUSH BAR
9	1	R-BASE-END	BASE RIGHT END
10	1	SUPPORT-PLATE	SUPPORT PLATE
11	1	THUMB-PULL	THUMB PULL
12	1	TOP-HANDLE-ASM	TOP HANDLE ASSEMBLY

HENNEPIN TECHNICAL COLLEGE BROOKLYN PARK & EDEN PRAIRIE, MN			TITLE: <h1 style="text-align: center;">HOLE PUNCHER</h1>		
UNLESS OTHERWISE SPECIFIED: DIMENSIONS ARE IN INCHES TOLERANCES: ANGULAR: ±.5° ONE PLACE DECIMAL: ±.03 TWO PLACE DECIMAL: ±.01 THREE PLACE DECIMAL: ±.005 INTERPRET GEOMETRIC TOLERANCES PER ASME Y14.5-2009			DRAWN QN 5/20/2022	NAME RJM 5/20/2022	DATE 5/20/2022
MATERIAL AS SHOWN			SIZE B	DWG. NO. HOLE-PUNCHER-ASM	REV 0
THIRD ANGLE PROJECTION			SCALE: .250	WEIGHT:	SHEET 1 OF 1