

REVISIONS			
REV.	DESCRIPTION	DATE	APPROVED
0	PRODUCTION RELEASE	5/12/2022	RJM

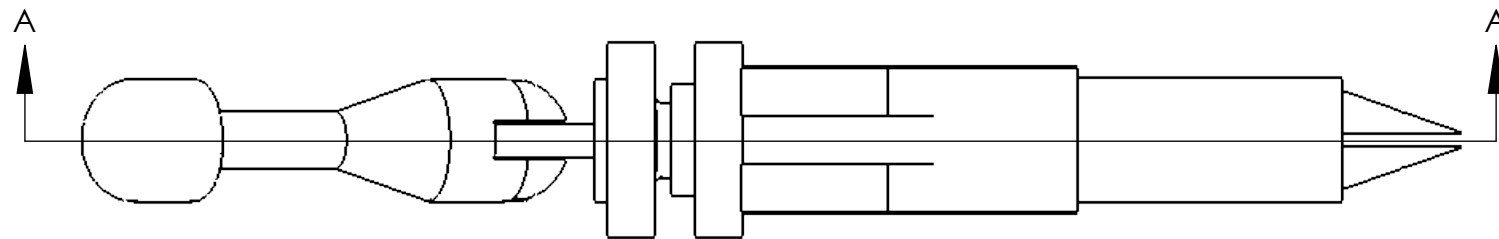
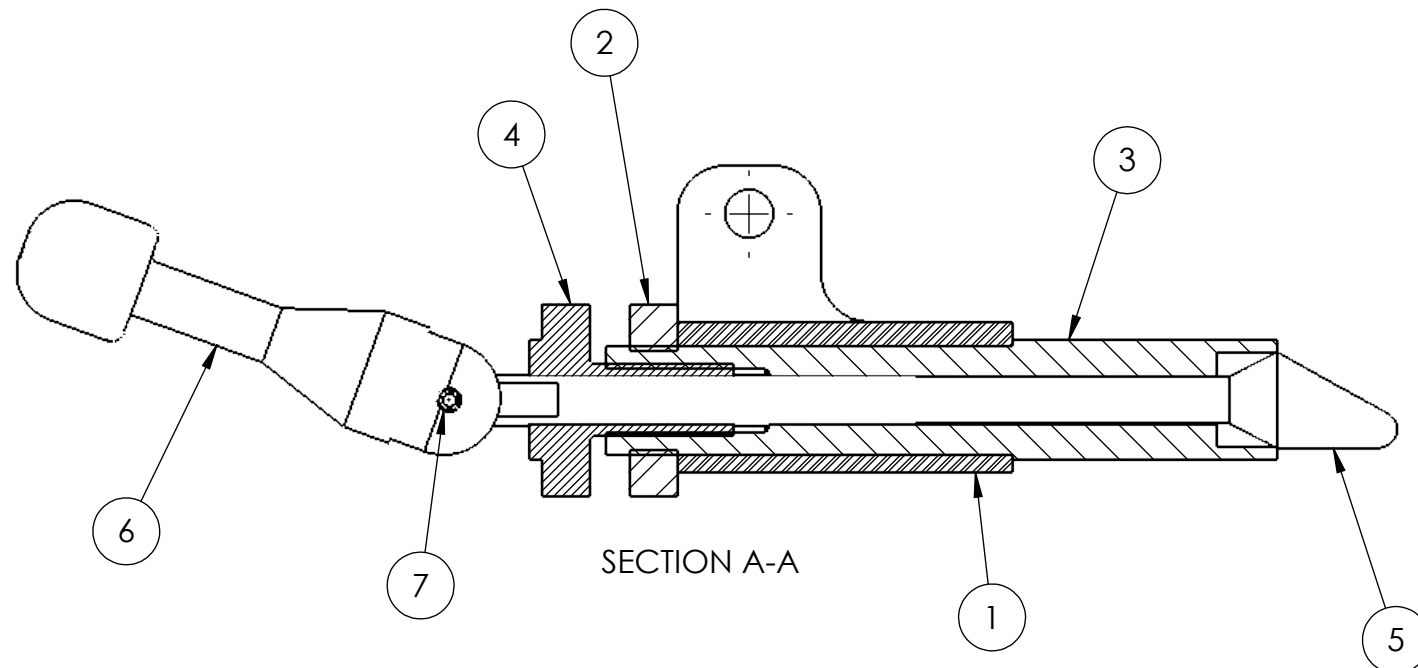

7	HSSS054416	#5-44UNF-3 X .5 LG HEX SOC SET SC	BLACK-OXIDE ALLOY STEEL	1
6	1DT1007	HANDLE CAM	SAE 1045	1
5	1DT1006	JAW SHAFT	SAE 1060	1
4	1DT1008	ADJUSTMENT KNOB	SAE 304	1
3	1DT1005	ROTATING HOUSING	SAE 304	1
2	1DT1009	NUT	UNS C36000	1
1	1DT1004	MAIN HOUSING	SAE 304	1
ITEM NO.	PART NUMBER	DESCRIPTION	MATERIAL	QTY.

HENNEPIN TECHNICAL COLLEGE BROOKLYN PARK & EDEN PRAIRIE, MN			TITLE UPPER VISE ASM			
<small>UNLESS OTHERWISE SPECIFIED: DIMENSIONS ARE IN INCHES TOLERANCES: ANGULAR: ±.5° ONE PLACE DECIMAL: ±.03 TWO PLACE DECIMAL: ±.01 THREE PLACE DECIMAL: ±.005 FOUR PLACE DECIMAL: ±.0005 INTERPRET GEOMETRIC TOLERANCES PER ASME Y14.5-2009</small>	DRAWN	QN	5/10/2022	SIZE B	DWG. NO. FTV01S01	REV 0
	CHECKED	RJM	5/10/2022			
	MATERIAL AS SHOWN			SCALE: 1:1	WEIGHT:	SHEET 1 OF 1
THIRD-ANGLE PROJECTION						